

Naim Audio have been manufacturing hi-fi electronics in the cathedral city of Salisbury since 1971. All the equipment that we sell is designed and made by us in our own factory, where every aspect of manufacture is under our direct control.

GLOSSARY

Many of the product names are acronyms.
Below is a current list.

NA	Naim Audio
NAC	Naim Audio Control unit
NAP	Naim Audio Power amplifier
NAT	Naim Audio Tuner
NA PST	Naim Audio Power Supply Tuner
NAXO	Naim Audio cross(X) Over
NAIT	Naim Audio InTegrated amplifier
SNAPS	Super Naim Audio Power Supply
SNAIC	Super Naim Audio Interconnect Cable
HI-CAP	High CAPacity power supply

The power amp type numbers are derived from the rated power into 4Ω both channels driven.

NAP 110 = 55 + 55 watts

NAP 140 = 70 + 70 watts

NAP 250 = 125 + 125 watts

NAP 135 (mono) = 135 watts

1 μ V = 1 microvolt = 0.000001V

1 mV = 1 millivolt = 0.001V

NA PST

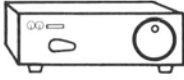

NAT 01

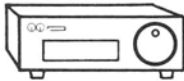

NAC 42-5

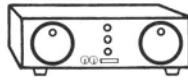

SNAPS

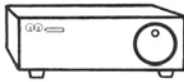

NAC 32-5

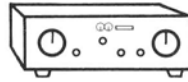

NAP 140

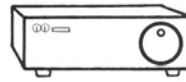

NAT 101

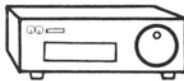

HI-CAP



NAP 250

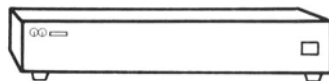

NAIT

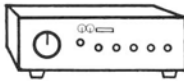

NAP 110



NAP 135

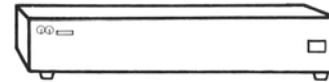

INSTALLATION INSTRUCTIONS

Please keep this manual safely. It will help you get the best out of your hi-fi system. It contains some general advice and guidance as well as instructions, and we hope you will find it useful for reference. Please read the section entitled WARNINGS carefully, before using the system.

YOUR DEALER

Normally your Naim equipment will have been installed by the dealer who sold it to you, even if you live outside his immediate area. Your dealer is responsible for making sure that the system sounds exactly as it should, and information given here is not intended to reduce this responsibility in any way.

CABLES AND CONNECTIONS

Please do not modify the standard interconnect cables supplied with amplifiers and power supplies, either the type of wire or length. This is important for safety as well as performance. One end of each cable is marked with a strip of tape, to establish its direction. The tape marks the end that goes towards the source. See picture on facing page. (This is explained further in sections for amps and power supplies.)

Speaker leads are also very important. Naim Audio speaker cable has the right specifications for your system, as have the 4mm banana plugs supplied with all our amplifiers. Your dealer will make up leads to your own requirements. They should be at least 3.5 metres long and of equal length. Like interconnect leads, this cable is directional: holding the cable so that the logo and name embossed on it read from left to right, the end on your left plugs into the speakers, that on the right into the amplifier. Incorrect cable will degrade performance, and some types may damage your amplifier.

The plugs and sockets that come with your equipment have been chosen because they make the best possible connection for their purpose. A poor contact will degrade the signal substantially, and plugs and sockets should all look clean and free from dirt and corrosion.

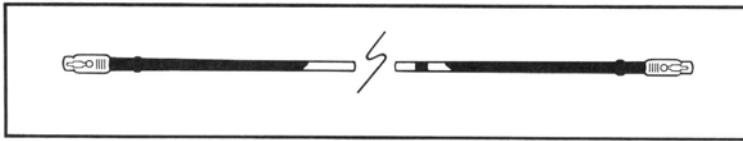

The easiest way to clean them is to pull the plugs out of their sockets and push them back in again. (WITH THE EQUIPMENT TURNED OFF). Special contact cleaners and "enhancers" should not be used, they deposit a film which degrades sound and is very difficult to remove. The connection between arm and cartridge is particularly important, but also delicate, so ask your dealer to see to maintenance.

TURNING ON AND OFF

Always switch the amplifier off before plugging (or unplugging) anything into the system, and wait about a minute for the power-supply capacitors to discharge.

If you have a separate power supply for your pre-amp, it's best to switch the power supply on first, and then the power amplifier. When turning off switch the amplifier off first, then the power supply. Some people prefer to leave the power supply for the preamp turned on permanently: the pre-amp takes a few hours to "warm up" properly, so leaving it on provides more consistent performance. If you have a system without a separate power supply, the pre-amp is being powered by a smaller supply inside the amplifier, and "warming up" is less important.

It's worth remembering that all electronic equipment can be damaged by lightning, including the electronic components of your hi-fi system. The amplifier is the most likely victim. Its mains lead should have an independent wall socket, so that it can be turned off when not in use, while the power supply (SNAPS or HI-CAP) is left on. For complete protection from lightning the mains (house current) plugs of all equipment should be pulled out, not just switched off, and any aerials disconnected.

MAINS SUPPLY

Where fused plugs are used, 13 amp fuses should be fitted. Smaller ones will fail after a period of use.

A hi-fi system usually shares a ring main with other household equipment, some of which can cause distortion of the mains wave-form, leading to mechanical hum from the transformers in amplifiers and power supplies. This hum is not transmitted through the speakers, has no effect on the system, but is purely local to the transformer itself.

A separate fused spur from the consumer unit (like the spur reserved for electric cookers) may reduce transformer noise. It's also worth bearing in mind that current from such a spur (ideally with a 30 amp rating) is cleaner and has lower impedance than that supplied on a ring main, and will improve performance.

Please don't wire V.D.R.s (voltage dependant resistors) into mains plugs, they degrade the supply, and the music.

HOW TO SITE EQUIPMENT

Power supplies and amplifiers need to be kept at a reasonable distance from the pre-amp, or their transformer fields will interfere with it, and cause hum audible from the speakers. 12" (300mm) is the minimum distance and that allowed by the standard interconnect lead is the maximum.

Turntables and loudspeakers should be sited according to manufacturer's instructions. There are two main objectives to bear in mind. The first is to keep the piece of equipment concerned absolutely stationary, in spite of its tendency to move in reaction to the forces being generated in it. The second is to avoid the equally unpleasant interreaction that will occur if equipment is coupled to large masses such as walls or heavy pieces of furniture. Placing a turntable on a large solid chest may meet the first objective but be horrible in terms of the second, so beware.

Improved design of turntables and speakers will eventually reduce the problems of acoustic coupling. Meanwhile, you will probably find that your turntable is best placed on a light but rigid surface such as a small, well-made coffee table. If a shelf is used it should be rested on its

supports rather than being fixed to them (to avoid coupling the shelf to the large mass of the wall behind.) The supports should be as nearly as possible under the feet of the turntable, to discourage the shelf from flexing. There are many specialist tables and stands available.

There should only be one pair of loudspeakers in the room. Please remember that each extra speaker in your listening room, even those in your TV set or telephone, will have a disproportionately confusing influence on sound waves.

SOURCES

The source of your music, whether record and turntable, broadcast and tuner, tape, tape deck or other, is the basis on which all the rest of the system depends. Turntables need particular care, and your dealer should check that your own is properly set up every time you improve any other part of the system.

WHEN YOU HAVE A PROBLEM

Legal consumer protection varies from country to country. In most places where our equipment is supplied, the dealer must be prepared to take back any Naim equipment he has sold you, at the time of sale, if he cannot make it work to YOUR satisfaction in your own home. A problem may be due to a fault in any part of your system, or its siting, so it is essential to make full use of your local dealer's diagnostic skills on site. Please contact your local distributor, or Naim Audio Ltd at the address in this manual, if any difficulties cannot be resolved. Much of our equipment is now made in special versions for different countries, adding to other obstacles that make it impracticable to arrange international guarantees, so please make sure of your position with your own dealer NOW, at the time of sale. We are always available to help and advise.

It is essential that repairs and modifications should only be carried out by an authorised Naim dealer, or at the factory by Naim Audio. Many components are made, tested or matched specially, and suitable replacements can only be obtained through ourselves.

CASE MAINTENANCE

Use a soft foam sponge that has been sprayed with an ordinary wax household polish.

Fascia panels should be wiped with a soft dry cloth.

INTEGRATED AMPLIFIER

An integrated amplifier has both the power amplifier and preamplifier stages of amplification fitted into a single case. This apparent simplicity requires a great deal of cunning. We hope you will enjoy your NAIT as much as Naim enjoyed designing it.

Low continuous power output is balanced by a very large peak current capacity, so there are no restrictions on the size or type of loudspeakers that may be used. But please don't expect the impossible. If you demand too much volume from your Nait using difficult speakers, the results will be increasingly disappointing.

The NAIT has three switch-selectable inputs, a phono input for moving magnet cartridges, a tuner input and a tape input. Either tuner or tape input may be used for compact disc. The tape socket combines input and output for recording and replay.

Tuner and tape connections are via 5-pin DIN sockets. Phono input is via RCA jack sockets. For loudspeaker leads and connections, please see the notes about speaker cables in the INSTALLATION INSTRUCTIONS section headed CABLES AND CONNECTIONS.

BALANCE AND VOLUME CONTROLS

The balance control affects the gain of the left channel only, plus or minus 3dB relative to the right channel, which is fixed. Setting the knob in the central position will not necessarily provide a central image, so this position is not marked on the amplifier. To adjust the balance, volume should be set at an average listening level, and the left channel brought up or down until it suits you. Further adjustment may be desirable during use, since the amount of information on each channel varies with different sources. A change of volume setting from low to high can also have an effect on the image. This is not a fault, but a function of the type of potentiometer used.

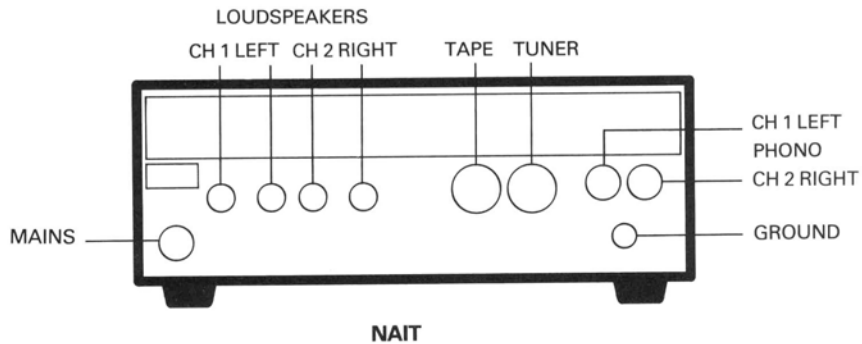

Input sensitivities

Phono:	2.5mV,	47k ohms.
Tuner and Tape:	75mV,	47k ohms.
	75mV,	1k ohm/source.

Tape output level and impedance:

The mains (house current) fuse is fitted inside the case. NEVER REMOVE THE NAIT'S COVER UNTIL ITS MAINS LEAD HAS BEEN DISCONNECTED FROM YOUR HOUSE CURRENT.

The mains earth (ground) should always be connected regardless of what other equipment is used with the NAIT.

Mains supply: 100V, 110V, 120V, 200V, 220V or 240V, 50 or 60Hz
 Case size: 76mm x 205mm x 276mm

PRE-AMPLIFIERS

Naim Audio preamplifiers may be used with a variety of power amplifiers besides our own. They require an external regulated power supply.

The power supply for your preamp is very important to its performance. The Naim NAP110 and 140 power amplifiers have a suitable regulated supply for the preamplifier built into them, though you may use a separate power supply if you wish. If you are using a Naim NAP 250 (or an amplifier made by another manufacturer) you will need a Naim SNAPS or HI-CAP preamp power supply. With NAP 135s, you will need a HI-CAP. More information about Power Supplies is on page 13.

A Link Plug is supplied with your preamp to fit the 240° 5 pin DIN socket on the right of the rear panel (the socket used for connection to a HI-CAP.) Leave the Link Plug in place unless you have a HI-CAP. If you forget, it will do no damage, but the preamp cannot function.

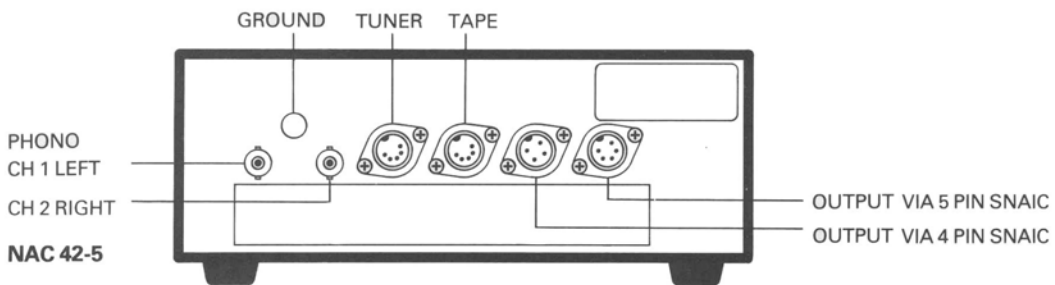

BASIC PREAMPLIFIER FACILITIES

The NAC 42-5 has three switch-selectable inputs, for phono, tuner and tape. Either tuner or tape input may be used for compact disc. The tape socket combines input and output for recording and replay. There is a mute/monitor switch.

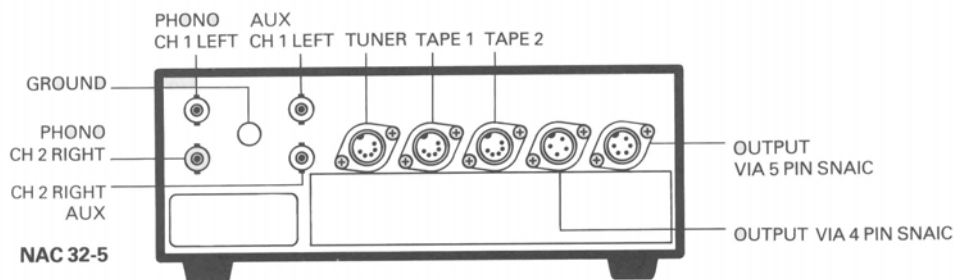

The NAC 32-5 has five switch-selectable inputs, one for phono, one variable auxiliary, one for tuner and two buffered inputs for tape. The auxiliary input is particularly suitable for compact disc, but either tuner or tape inputs may be used if desired. Tape sockets combine input and output for recording and replay.

TAPE FACILITIES AND MONITOR SWITCH

Tape input sensitivity
Tape output level and impedance

75mV, 100k ohms.
75mV, 600 ohms.

The tape monitor switch allows you to listen to the output of the tape recorder whilst recording the source that you have chosen with the selector switch. This can be useful with a 3-head machine to monitor the "off-tape" signal while making a recording.

In the "normal" position, the source selected will be fed to the power amp. In the "monitor" position, the output from tape 1 will be heard, unless tape 1 is chosen on the selector switch, when the output of tape 2 will be heard.

With the monitor switch set at "mute", there will be no output to the speakers, from any input.

PHONO OPTIONS

The following types of board to suit different inputs are completely interchangeable in all preamps:

	Sensitivity	Impedance
NA 323S for low-output moving coil cartridges	100 μ V	470 ohms
NA 322 for high-output moving magnet cartridges	2 mV	47K ohms
NA 323K for Linn Karma cartridge only	100 μ V	560 ohms
NA 326 for high-level inputs	75 mV	100K ohms
NA 328 has variable sensitivity for high-level inputs	25 mV-375 mV	47K ohms

The pre-set on the NA 328 should be adjusted using a small insulated shaft screwdriver; turn anti-clockwise for maximum gain, clockwise for minimum gain. Turn fully clockwise for use with CD players.

HEADPHONES

For low impedance headphones see POWER AMPLIFIER section. Headphones with an impedance of 600 ohms or higher can have a specially wired 4 or 5-pin connection straight to the preamplifier. Please consult your dealer.

CONNECTIONS

Please read the paragraphs headed CABLES AND CONNECTIONS in the INSTALLATION INSTRUCTIONS section. Never disconnect any leads, except the mains (house current) lead or move equipment about in such a way as to disturb connections, unless the amplifier is switched off.

Naim preamplifiers use BNC sockets for phono input. If your tone arm cable has an unsuitable termination, your dealer will convert it with the BNC plugs supplied.

Output to the amplifier is delayed until voltages in the preamplifier have reached operating level, when you will hear a noticeable soft "plop" as the relay circuit allows the preamp to turn on.

OTHER SPECIFICATIONS

Tape, tuner, and NA 326 conversion of phono input, will accept up to 7.5V rms and are thus suitable for the output from a professional tape recorder or a compact disc player.

Overload margins: 40dB on all inputs at all audio frequencies.

Main outputs: Level: 1V Impedance: 47 ohms. Case size: 76 mm x 205mm x 300mm.

HI-CAP LABEL

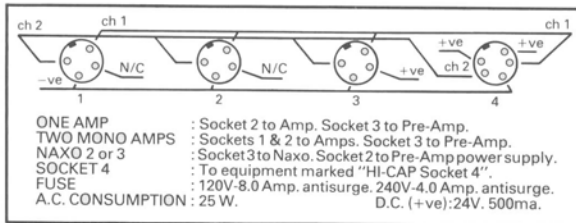

SOCKET 4 : This applies to -4 -5 and -6 products.

SNAPS LABEL

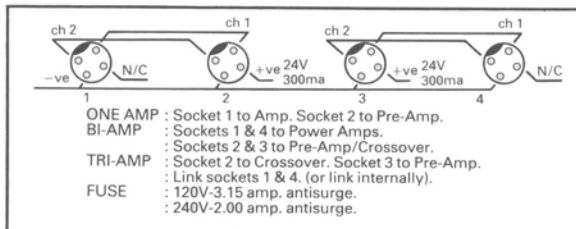

An adequate and correctly designed power supply is extremely important to the performance of the preamplifier. A separate power supply is not required when Naim preamplifiers are used with the NAP 110 or 140, but optional use of the SNAPS 24V supply offers the benefit of a larger and quieter power source.

The HI-CAP offers even better performance. This is a much larger dual 24V supply for use with -5 preamplifiers, or the NAXO 2-4 or 3-6 crossover. An alternative socket is provided for earlier preamplifiers or crossovers.

CABLE CONNECTIONS

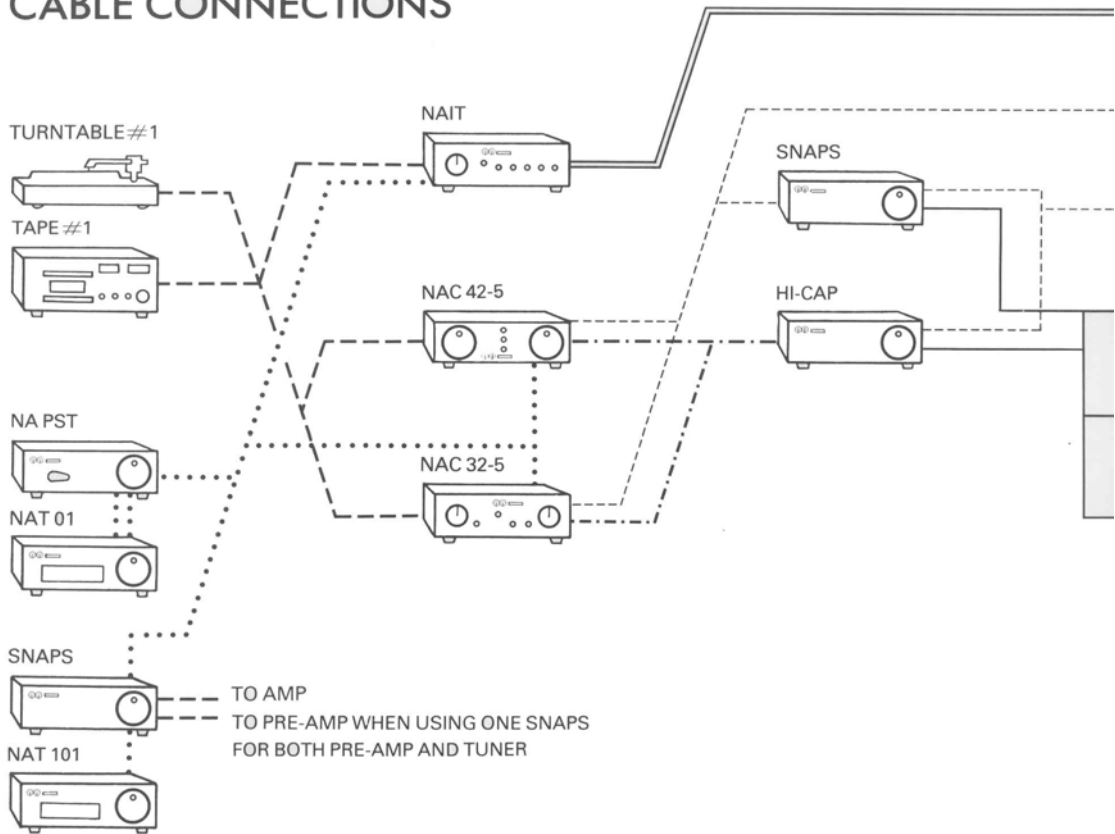

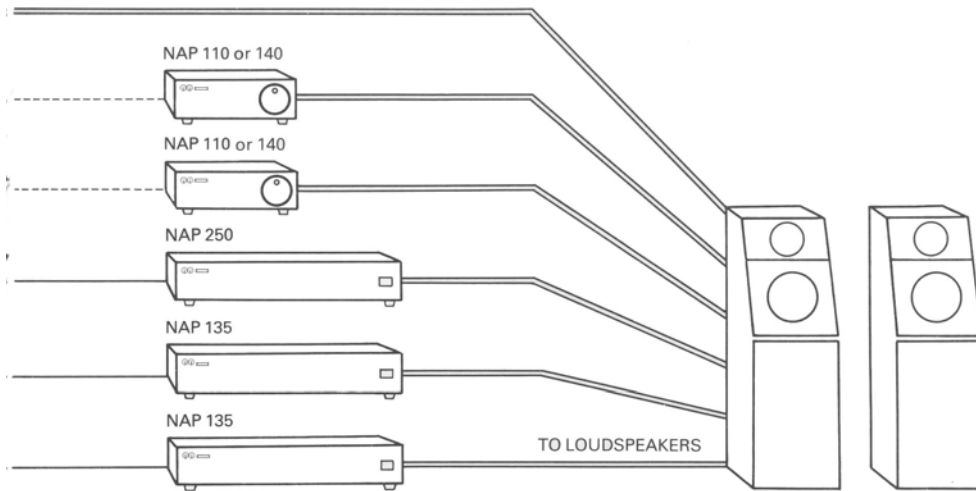

KEY TO CONNECTING CABLES

- | | | | |
|-------|------------------------|-------|--|
| ----- | As supplied | ===== | NAC A4 Speaker Cable |
| ----- | SNAIC 4 to 4 pin DIN | | As supplied – for full interconnection details see tuner manual. |
| ----- | SNAIC 5 to 5 pin DIN | | |
| ----- | 4 pin DIN to 3 pin XLR | | |

BI-AMP CABLE CONNECTIONS

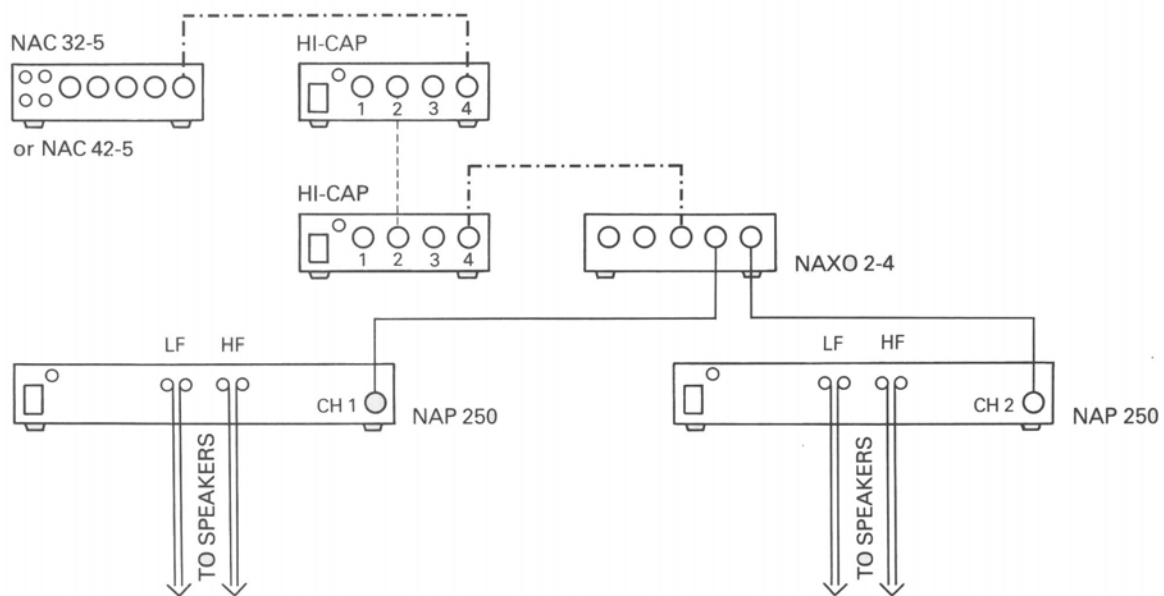

KEY TO CONNECTING CABLES

SNAIC 5 to 5 pin DIN	-----	SNAIC 4 to 4 pin DIN	-----
4 pin DIN to 3 pin XLR	—————	NAC A4 Speaker Cable	===== =====

FOUR-PACK CABLE CONNECTIONS

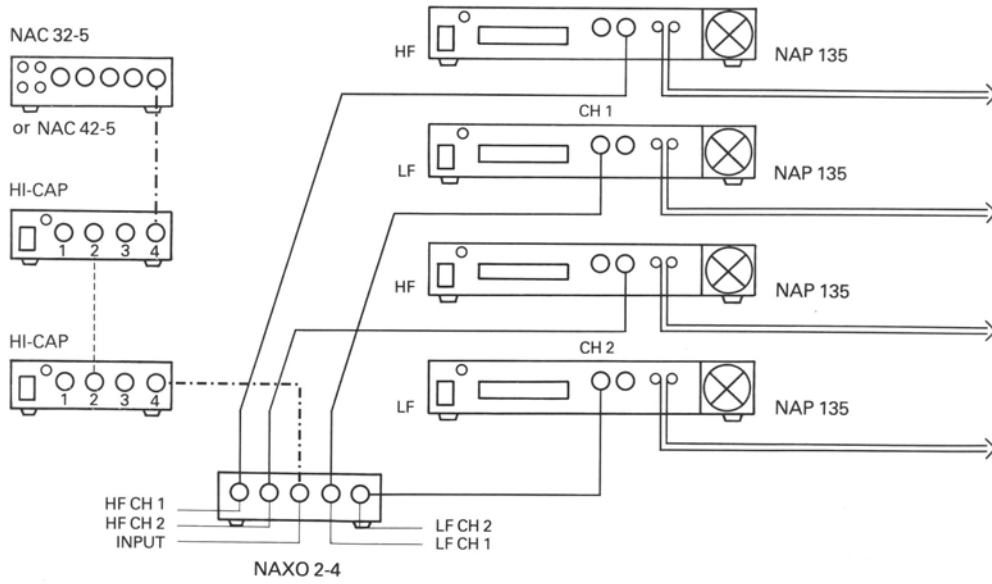

TRI-AMP CABLE CONNECTIONS

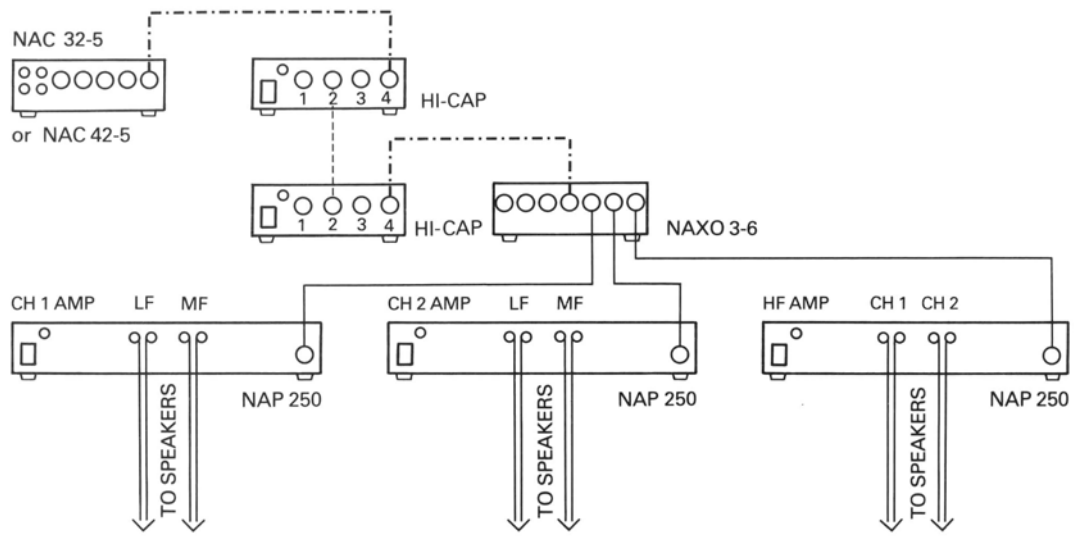

KEY TO CONNECTING CABLES

SNAIC 5 to 5 pin DIN	-----	SNAIC 4 to 4 pin DIN	-----
4 pin DIN to 3 pin XLR	_____	NAC A4 Speaker Cable	=====

SIX-PACK CABLE CONNECTIONS

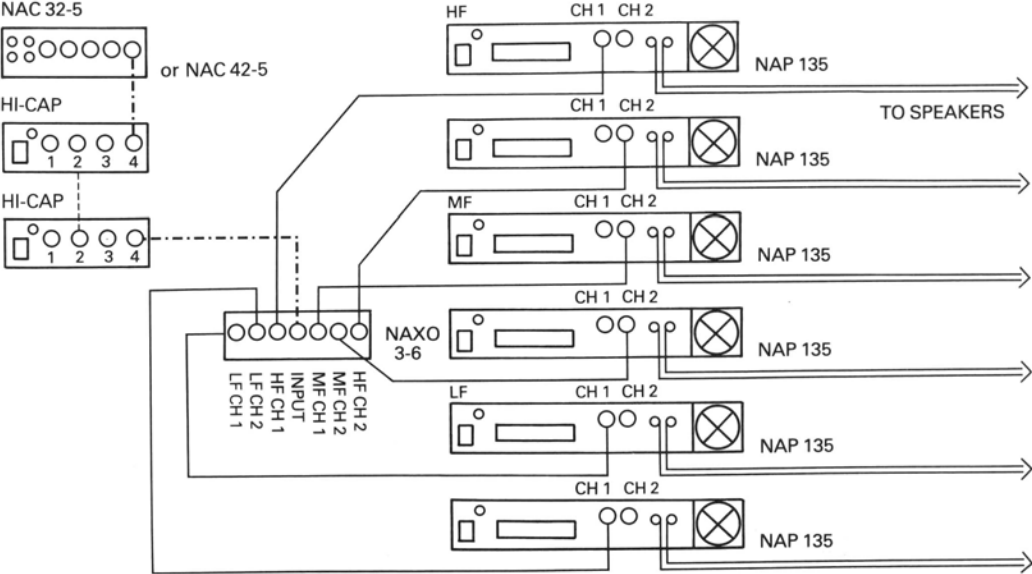

POWER AMPLIFIERS

Naim Audio power amplifiers should only be used with Naim pre-amplifiers. This is very important, since operating conditions for the amplifier are defined by the pre-amplifier. The use of a passive volume control is not recommended. It will seriously limit the bandwidth in the audible region, and the stability of the amplifier may be compromised. Any damage resulting from use without a Naim pre-amplifier is likely to invalidate warranties.

GENERAL

The negative input and output connections are all common.

The mains earth (ground) should always be connected regardless of what other equipment is used in conjunction with Naim power amplifiers. This only grounds the case and the electrostatic screen within the transformer, and is not connected to the signal negative. In order to avoid hum loops, the signal negative of the whole system should be connected to the mains earth (ground) in ONE place. This will normally be at the turntable.

CONNECTIONS

The NAP 110 and 140 can be used with or without a separate pre-amp power supply. When it is used on its own, the signal is carried from the pre-amp to the power amp using the SNAIC-4 interconnect lead supplied, and the same lead takes the DC supply from the NAP 110 or 140 to power the pre-amp.

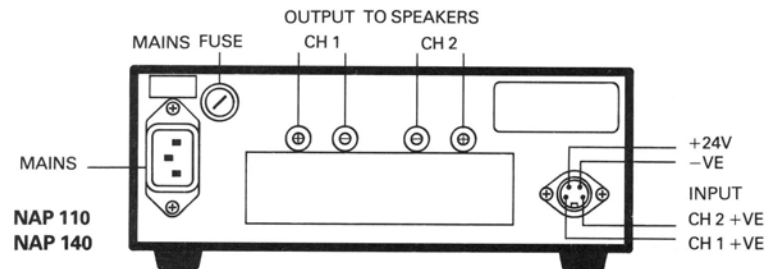

When the 110 or 140 is used with a SNAPS or HI-CAP to power preamplifier, the SNAIC-4 interconnect takes the signal from the power supply instead of from the pre-amp. Please see the diagrams on pages 14 and 15.

The NAP 250 and NAP 135 are always used with a separate power supply. Either a SNAPS or a HI-CAP can be used with the 250, but the 135 always requires a HI-CAP. In both cases the signal is taken from the power supply via a 4 pin DIN to 3 pin XLR interconnect.

When connecting a pair of NAP 135s to their HI-CAP, make sure that one of the XLR leads from the HI-CAP goes to the socket marked 'Left Channel' on one NAP 135 and the other XLR lead goes to the socket marked 'Right Channel' on the other NAP 135.

DO NOT USE NON-STANDARD INTERCONNECTING LEADS.

DO NOT UNDER ANY CIRCUMSTANCES PLUG OR UNPLUG THE INPUT WHILE THE AMPLIFIER IS TURNED ON, OR DAMAGE MAY RESULT TO BOTH THE AMP AND SPEAKERS.

PROTECTION

If the cases of the NAP 110, 140 or 250 reach 70°C due to prolonged running at high dissipation, the mains supply will be interrupted and the indicator light will go off until the amplifier has cooled down. This may take up to 30 minutes. There is no need to turn the amplifier off, but the sudden return of full volume when it has cooled down can be surprising, and you may prefer to turn down the volume on the pre-amp.

The regulated power supplies in the NAP 250 will shut down if more than 17 amps is drawn for more than 10 microseconds, but the indicator light will not go off. To reset, turn the amplifier off for 1 minute.

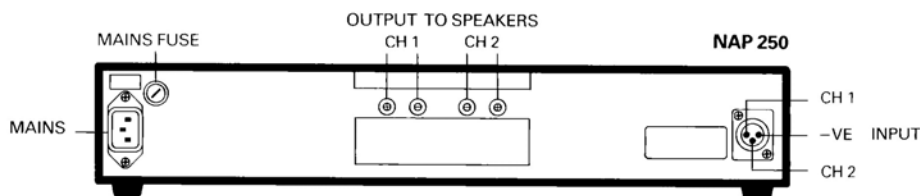

In the NAP 135, fan speed is increased in response to an increase in amplifier dissipation. If the heatsink of the NAP 135 reaches 70°C due either to prolonged running at very high dissipation, blocked airflow, or fan failure, the mains supply will be interrupted and the indicator light will go off until the amplifier has cooled down. This may take up to 30 minutes. There is no need to turn the amplifier off, but reducing volume will avoid surprises. The regulated power supply will shut down if more than 18 amps is drawn for more than 10 microseconds, but the indicator light will not go off. To reset, turn the amplifier off for 2 minutes.

LOW IMPEDANCE HEADPHONES

Introducing any form of switch in the output of the amplifier degrades sound quality, so if you wish to use headphones with Naim amplifiers, the loudspeakers must be disconnected and the headphones substituted.

Care is required in the choice and use of headphones, both for safety and satisfactory results. Some electrostatic headphones have a combination of reactance which is not isolated by normal speaker cables, giving an unbalanced frequency response. It should also be borne in mind that Naim amplifiers have a common earth. So if headphones with a common earth are connected the wrong way round, both headphones and amplifier may be damaged.

SPEAKER CABLE

For best results Naim Audio's own speaker cable should be used to connect a loudspeaker to the output of the amplifiers. Alternatively use two conductors 4 sqmm single core multistrand wire (R.S. type 357-946) lightly twisted together, about 4 turns per metre. Suitable 4mm connectors are supplied to make the connection to the amplifier.

DO NOT, FOR ANY REASON, USE SO CALLED HIGH DEFINITION WIRE OR ANY OTHER SPECIAL CABLE BETWEEN AMPLIFIER AND LOUDSPEAKER.

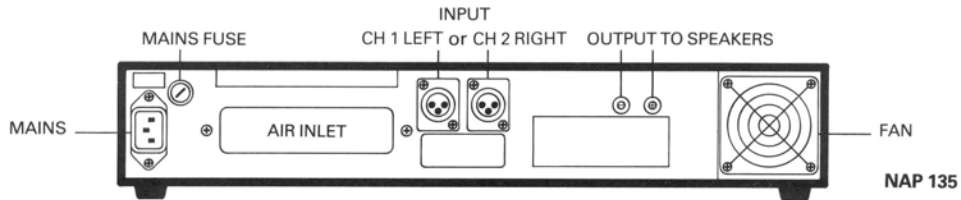

Naim Audio Equipment is designed to offer the finest sound quality that can be achieved, avoiding compromise whenever possible. This can lead to situations that may be unfamiliar. The material that follows contains advice and information specifically related to Naim equipment, as well as more general warnings about the use of domestic amplification, so please make sure you read it carefully.

1. Naim pre-amplifiers are supplied with BNC sockets on the phono input. The impedance of the more common RCA (phono) socket does not match the majority of arm cables, and your BNC sockets **MUST** be used if you wish to realise the full potential of your Naim equipment. Their method of operation also provides a slight extra safety factor. Unlike the BNC, the RCA socket breaks the ground before the signal, and can therefore cause damage to speakers if plugged or unplugged whilst the equipment is turned on.
2. The transformers in the amplifiers and power supplies may sometimes make a mechanical noise caused by distortion of the mains (house current.) Naim transformers are large in size and have large gauge secondary windings, making them quite sensitive to this distortion. A separate spur from your consumer unit for your Hi-Fi system can often reduce the effect, while also giving an overall improvement in sound quality, but it may be necessary to take account of mechanical transformer noise when siting your equipment.
3. In some circumstances you may experience Radio Frequency interference, depending on where you live and the earthing arrangements in your home. Controls on broadcasting in some countries are such that very high levels of RF are present, and due to the wide bandwidth design necessary for sound quality that meets our standards, the choice and siting of the equipment may sometimes be critical. If you have a problem in your area, arrange for a home demonstration before purchase to find out if Naim equipment will be affected. In general both moving magnet pre-amps and passive systems are less subject to the effects of RF interference. In extreme cases customers may be better off with amplification with a more limited bandwidth, and Naim equipment will be unsuitable.
4. The electronic components of your hi-fi system can be damaged by lightning. The amplifier is particularly sensitive to adverse conditions during an electrical storm, and should always be turned off when not in use. For complete protection, the mains (house current) plugs of all equipment should be pulled out, and any aerials disconnected.
5. Whenever connecting or disconnecting either your Naim electronics or ancillary equipment **ALWAYS** switch off the power first, then wait at least one minute before proceeding.
6. **EQUIPMENT IS DESIGNED TO CONFORM TO BS415:1979 AND SIMILAR INTERNATIONAL SAFETY REQUIREMENTS.**
7. **FOR YOUR OWN SAFETY, DO NOT UNDER ANY CIRCUMSTANCES OPEN NAIM EQUIPMENT WITHOUT FIRST DISCONNECTING THE MAINS (HOUSE CURRENT).**
8. **DO NOT UNDER ANY CIRCUMSTANCES ALLOW ANYONE TO MODIFY YOUR NAIM EQUIPMENT WITHOUT FIRST CHECKING WITH YOUR DEALER, DISTRIBUTOR OR THE FACTORY.**